



eHome Link T2C16 TRI

eHome Link T2C16 TRI, Car park wall box

Code: V25390.

- > Output type: 400 Vac - 16 A - 11 kW
- > Input current: 16 A
- > Connector type: Type 2 cable
- > Grid type: Three-phase
- > Charge mode: 3
- > No. Sockets: 1
- > Earth leakage protection: 6 mAdc

Description

Designed to be easily installed in both indoor and outdoor private parking spaces, and to be distributed to electric vehicle manufacturers. The eHome range has been optimised to offer the best cost/quality ratio on the market. As a result, we offer a high quality product that can comfortably charge all the electrical vehicle brands on the market in Mode 3 with a Type 1 or Type 2 connector.

Thanks to its compatibility with the **CirBEON-63** device, which manages the current supplied to the vehicle based to the power available, the **eHome** charger is ideal for the domestic sector.

Application

Its application focuses on home use, since it is easy to install and comes in a small size.



eHome Link T2C16 TRI

Basic charging wallbox

Code: V25390.

Specifications

AC power supply

Input intensity	16A
Frequency	50 / 60 Hz
Type of network	3Ph + N + GND
Nominal voltage	400 V ~ ($\pm 10\%$)

Electrical characteristics

Cable: Connector type	Type 2 cable
Max. output intensity (A)	16
Charging mode	Mode 3
No. of charges	1
Max. output power (kW)	11
Voltage	400 V ~ ($\pm 10\%$)

Mechanical characteristics

Size (mm) width x height x depth	180 x 315 x 115 (mm)
Envelope	Self-extinguishing ABS-PCV0 plastic
Fastening	Wall mounting, 3-point wall anchorage
Weight (kg)	4

Environmental characteristics

Protection class	IP 54
Relative humidity (without condensation)	100%
Working temperature	-30°C ... +50°C

User interface

LED	Charge indicator
-----	------------------

Standards

Standards	IEC 61851-1, IEC 61851-21-2, IEC 62196-1, IEC 62196-2, Directiva 2014/35/UE, LVD; 2014/30/UE, EMC
-----------	---

Features / performance

Optional	Protection shutter Max. Current controller (CirBEON)
----------	--

Protection

Element	DC 6 mA leakage detector Overvoltage detector Overtemperature
---------	---

Output 1



eHome Link T2C16 TRI

Basic charging wallbox

Code: V25390.

Maximum current	16 A
Maximum power	11 kW
Voltage range	400 Vac
Connector type	Type 2 cable
Network type	Three-phase (AC)

eHome Link

Home charging stations with RS-485 communications

CODE	TYPE	Output type	Connector type	Grid type	Earth leakage protection
V25330.	eHome Link T2C32	230 Vac - 32 A - 7,4 kW	Type 2 cable	Single-phase	6 mAdc
V25370.	eHome Link T2S32	230 Vac - 32 A - 7,4 kW	Type 2 socket	Single-phase	6 mAdc
V25380.	eHome Link T2S16 TRI	400 Vac - 16 A - 11 kW	Type 2 socket	Three-phase	6 mAdc
V25390.	eHome Link T2C16 TRI	400 Vac - 16 A - 11 kW	Type 2 cable	Three-phase	6 mAdc

End-of-charge light, Compatible only with CirBEON-63 sensor, Weight: 4 kg, ABS-PCV0 self-extinguishing plastic housing - IP54 - IK10, Dimensions 315x180x115 mm. 5-m cable length, cable holder included (depending on model).



eHome Link T2C16 TRI

Basic charging wallbox

Code: V25390.

Dimensions

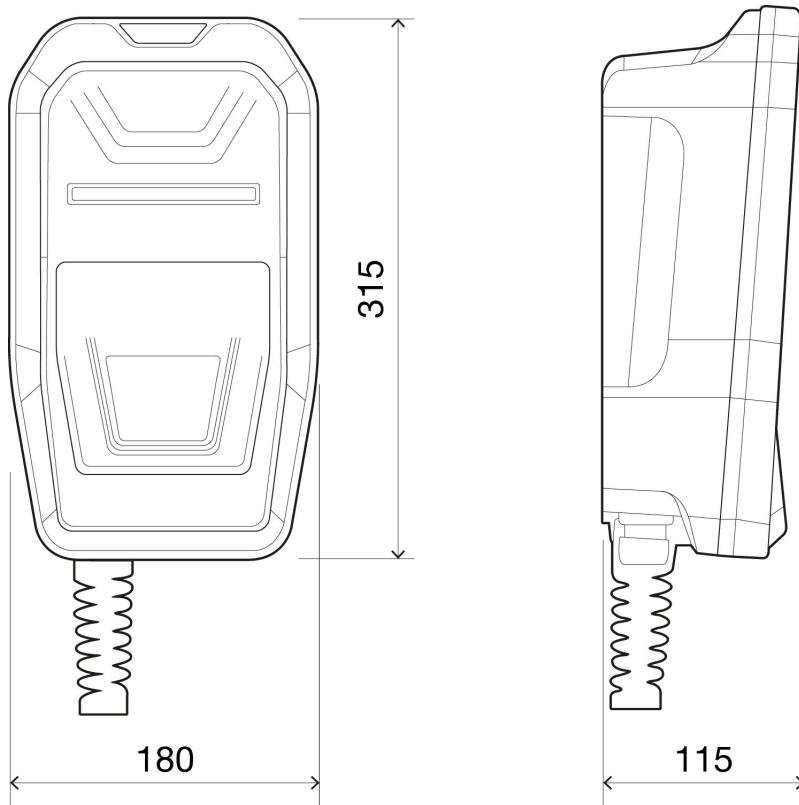

Connections

Three-phase Charge Point

Connect to the **400V ~**.
 (If the Power Supply is Single-Phase, connect L1 and N)

