



eHome T1C16 N

eHome T1C16 N

Code: V25100. DESCATALOGADO

- > car park wall box
- > Output type: 230 V - 16 A 3,7 kW
- > Input current: 16 A
- > Connector type: Type 1 cable
- > Charge mode: 3
- > No. Sockets: 1

Description

Designed to be easily installed in both indoor and outdoor private parking spaces, and to be distributed to electric vehicle manufacturers. The eHome range has been optimised to offer the best cost/quality ratio on the market. As a result, we offer a high quality product that can comfortably charge all the electrical vehicle brands on the market in Mode 3 with a Type 1 or Type 2 connector.

Thanks to its compatibility with the **CirBEON-63** device, which manages the current supplied to the vehicle based to the power available, the **eHome** charger is ideal for the domestic sector.

Application

Its application focuses on home use, since it is easy to install and comes in a small size.



eHome T1C16 N

Basic charging wallbox

Code: V25100.

Specifications

Mechanical characteristics

Size (mm) width x height x depth	180 x 315 x 115 (mm)
Envelope	Self-extinguishing ABS-PCV0 plastic
Fastening	Wall mounting, 3-point wall anchorage
Weight (kg)	4

Environmental characteristics

Protection class	IP 54 / IK 10
Relative humidity (without condensation)	5% ... 95%
Storage temperature	-40°C ... +60°C
Working temperature	-5°C ... +45°C

Features / performance

Heating and air conditioning unit	-30 ... +45 °C (Optional)
-----------------------------------	---------------------------

eHome

Home charging stations

CODE	TYPE	Output type	Connector type	Grid type
V25030.	eHome T2C32	230 Vac- 32 A - 7,4 kW	Type 2 cable	Single-phase
V25070.	eHome T2S32	230 Vac- 32 A - 7,4 kW	Type 2 socket	Single-phase
V25080.	eHome T2S16 TRI	400 Vac - 16 A - 11 kW	Type 2 socket	Three-phase
V25090.	eHome T2C16 TRI	400 Vac - 16 A - 11 kW	Type 2 cable	Three-phase

End-of-charge light, Compatible with CirBEON-63 sensor, Weight: 3 kg, ABS-PVC0 self-extinguishing plastic housing - IP54 - IK10, Dimensions 315x180x115 mm. 5-m cable length, cable holder included (depending on model).



eHome T1C16 N

Basic charging wallbox

Code: V25100.

Dimensions

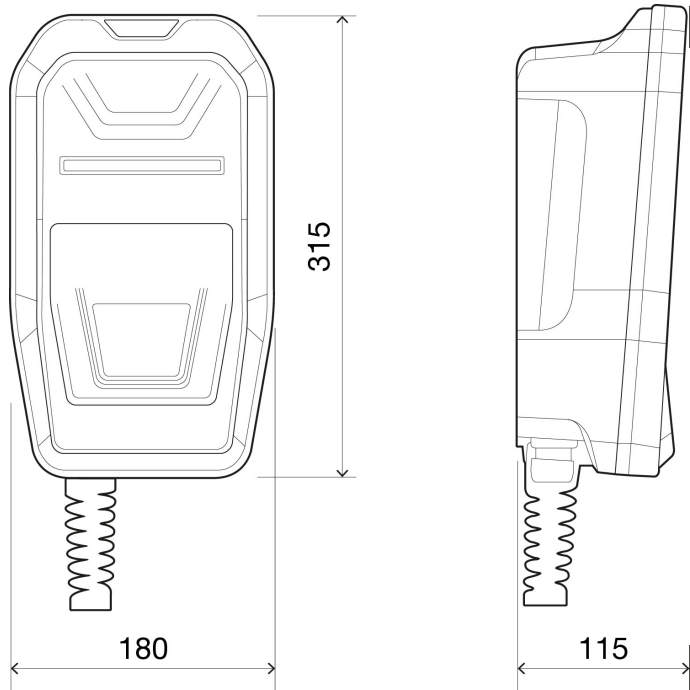

Connections

