



Antena mural

Indoor wall antenna 2.2 dBi 2m,

Code: Q4994M.

Description

ePick GPRS VPN or ePick GPRS NET. It is a **datalogger** or **gateway** designed to connect all of your installation's devices and sensors in order to facilitate electric energy management together with the **CIRCUTOR DataBox platform**.



Antena mural

Gateway for DataBox platform

Code: Q4994M.

Specifications

Mechanical characteristics

Size (mm) width x height x depth 30 x 241 x 115 (mm)

Environmental characteristics

Working temperature -40 ... 85 °C

ePick-Accessor
Accessories

CODE	TYPE
Q4994M.	Antena mural
Q4994N.	Antena antivandálica



Antena mural

Gateway for DataBox platform

Code: Q4994M.

Dimensions

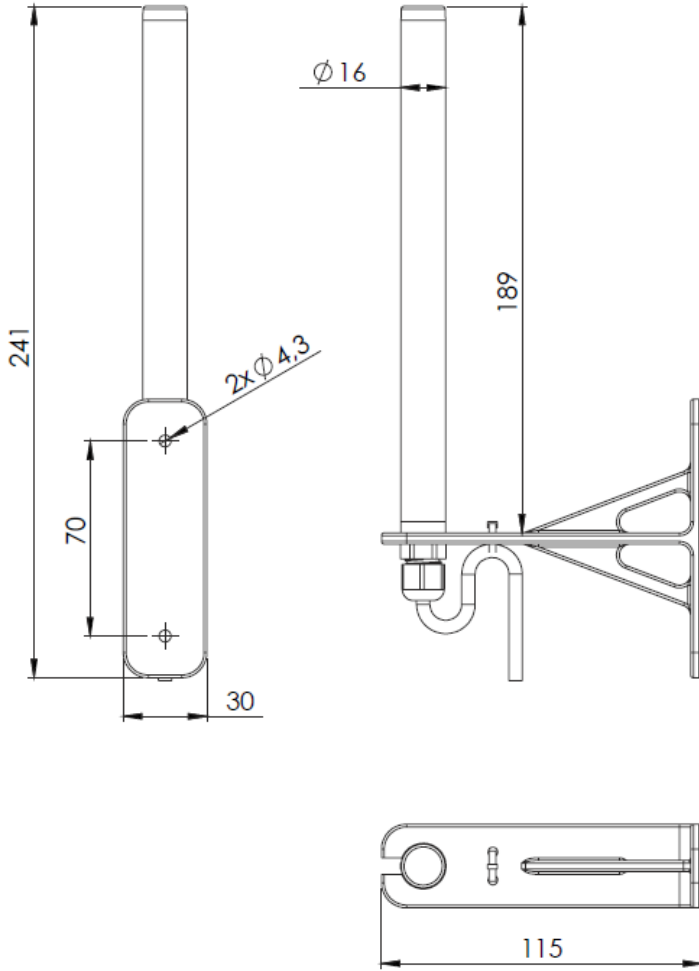

Connections

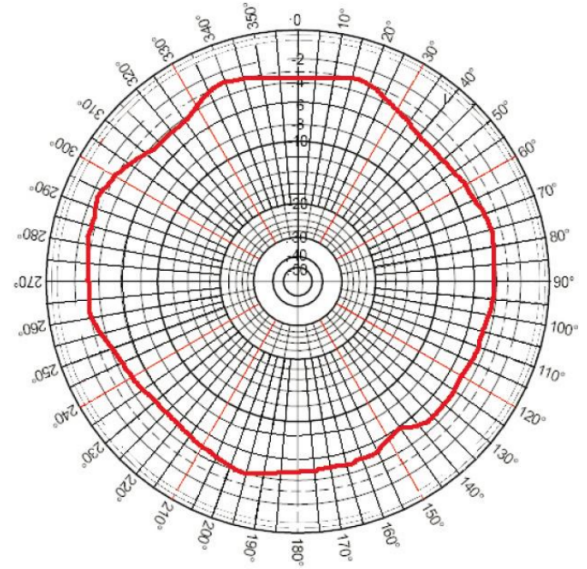

Diagrama acimutal (plano X, Y o E)

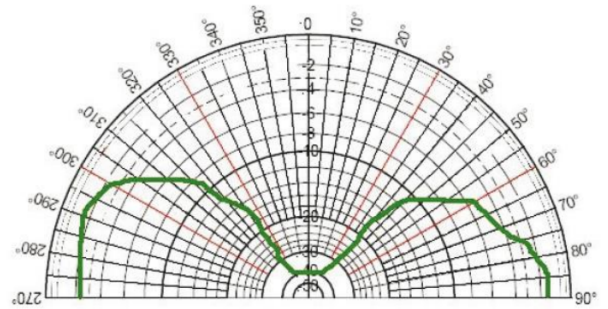

Diagrama de elevación (plano Z, Y o H)