



## Compact DC 3G

Compact DC 3G, PRIME PLC Concentrator

Code: Q46010. **DESCATALOGADO**

- > 2º transformer connection: No
- > RF Display Communication: No
- > Measure VN-GND: No
- > Communications: PRIME | 3G
- > Digital inputs: 0
- > LV supervisor: 1

### Description

The **COMPACT DC** concentrator is the device used to manage and read three-phase and single-phase power meters connected to the same low-voltage network using PRIME communications.

Typically located in the transformer substation, the **COMPACT DC** concentrator provides telemanagement features for the meters, whether reading the information they provide, or executing the actions that can be applied to this type of device, such as modifying tariffs, actuating the circuit breaker, etc.

**COMPACT DC** has an indirect three-phase meter with low-voltage monitoring functions, depending on the model.

The device features PRIME PLC communications, an Ethernet port and digital inputs.



## Compact DC 3G

PLC PRIME Concentrator

Code: Q46010.

### Specifications

#### Mechanical characteristics

Size (mm) width x height x depth	203 x 120 x 130 (mm)
Weight (kg)	130

Isolated digital inputs, 10 kV/1 min



## Compact DC 3G

PLC PRIME Concentrator

Code: Q46010.

## Dimensions

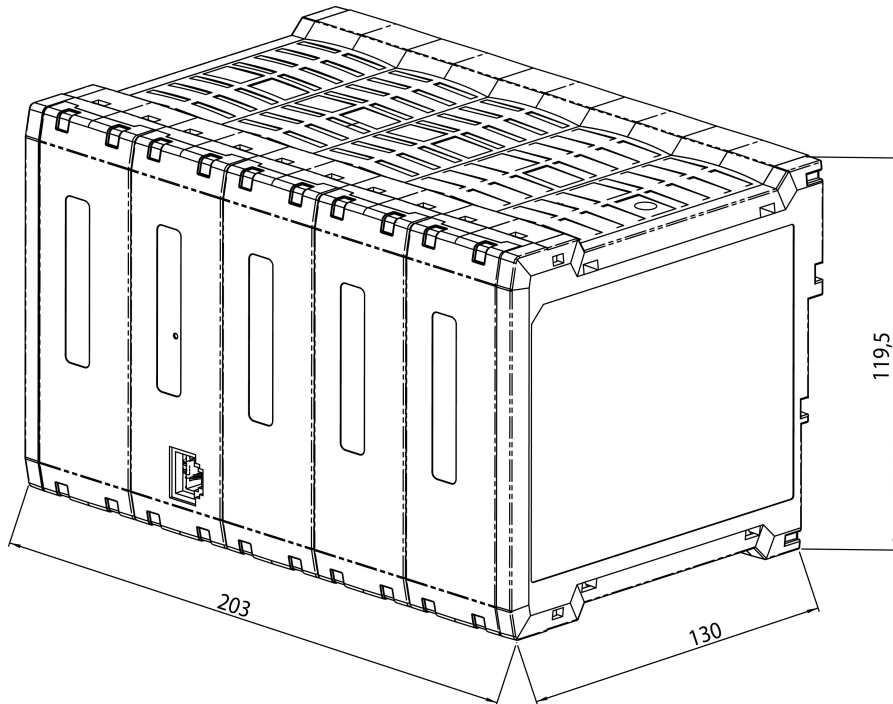

ESCALA 1 : 1