

CAP-CRADY-T2 400A

CAP-CRADY-T2 400A, Low voltage output module for vertical three-pole base 400A, size 2 Crady,

Code: Q32100. [CONSULTAR DISPONIBILIDAD](#)

Description

CAP is the base that is installed at the output of the low voltage panel, which incorporates three busbars with individual current transformers, and a connector for measuring voltage. These signals are captured directly via the T-SABT card for monitoring and calculating the electrical parameters.



CAP-CRADY-T2 400A

Low-voltage output meter

Code: Q32100.

Specifications

Mechanical characteristics

Size (mm) width x height x depth	98 x 162 x 195 (mm)
Weight (kg)	2,2



CAP-CRADY-T2 400A

Low-voltage output meter

Code: Q32100.

Dimensions

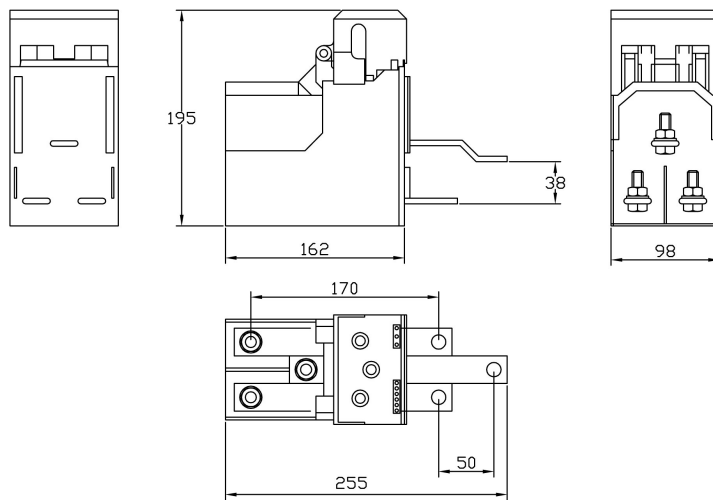

Vista con la tapa abierta