



CEM-C6-MID

CEM-C6-MID, Single-phase energy meter, direct connection

Code: Q26115. [CONSULTAR DISPONIBILIDAD](#)

- > Protocol: Modbus/RTU
- > Módulos: 1
- > Certification: MID
- > Communications: RS-485
- > System: Single-phase
- > Measure: Direct
- > Measurement Range (V): 1 x 230
- > Measurement Range (A): 10 (100) A
- > Quadrants: 2

Description

CEM-C6 is a single-phase electrical energy meter that can measure up to 100 A, is capable of measuring energy in two directions and has Class 1 accuracy. In addition, the meter features a built-in RS-485 / Modbus RTU communication system.

Other features:

- Complies with the **IEC 62052-11** and **IEC 62053-21** standards (general and specific requirements of measuring units)
- Compact dimensions (1 DIN rail module, 18 mm)
- Backlit LCD display (6 digits) with a scrolling screen system used to display the electrical parameters (V, A, kW, kvar, kVA, kWh and $\cos \varphi$).

Application

- Measurement of the consumption of electricity in buildings, machinery or the tertiary sector.
- Control of consumption with a multi-tariff function, to measure the consumption of each period
- Energy consumption is reported to a remote system.



CEM-C6-MID

Single-phase electrical energy meter, for assembly on DIN Rail

Code: Q26115.

Specifications

AC power supply

Nominal voltage	230 V ~
-----------------	---------

Mechanical characteristics

Size (mm) width x height x depth	18 x 90 x 72 (mm)
Envelope	ABS, PC alloy material
Weight (kg)	0,098

Environmental characteristics

Protection class	IP 51
Relative humidity (without condensation)	95 %
Working temperature	-20 ... +65 °C

Current measurement circuit

Nominal current (In)	10 A
Maximum current	100 A

Voltage measurement circuit

Nominal frequency	50 Hz.
Maximum input voltage consumption	$\leq 8 \text{ VA}$, $\leq 0,4 \text{ Wh}$

User interface

LED	1000 imp / kWh (amplitude: 90 ms)
Keyboard	1 Keys
Display type	LCD
Maximum value	99999,9 kWh

Measurement accuracy

Active energy measurement (kWh)	Class 1 (IEC 62053-21)
---------------------------------	------------------------

Serial communication

Protocol	Modbus RTU
Technology / Type	RS-485

Frequency: 50/60 Hz. Parameters: V, A, kW, kVA, kWh, cos phi



CEM-C6-MID

Single-phase electrical energy meter, for assembly on DIN Rail

Code: Q26115.

Dimensions

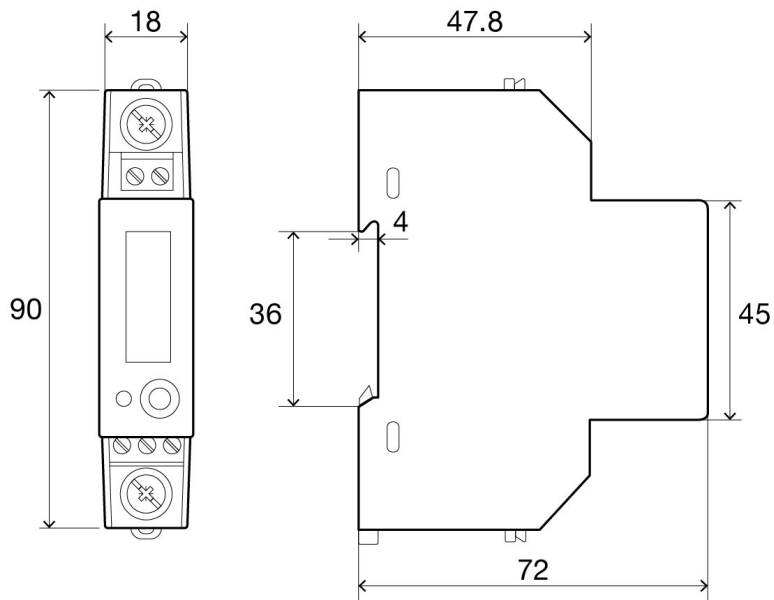

Connections

