



CEM-C31-485-DS-MID

CEM-C31-485-DS-MID, Indirect three-phase energy meter with MID certificate

Code: Q23532. **CONSULTAR DISPONIBILIDAD**

- > Protocol: Modbus/RTU
- > Módulos: 4
- > Tariff: 2
- > Certification: MID
- > Communications: RS-485
- > Digital inputs: 1
- > System: Three-phase
- > Measure: Indirect
- > Measurement Range (V): 3 x 57/100...3 x 230/400
- > Measurement Range (A): .../ 5 (10) A
- > Max. Current (A): 10

Description

Three-phase electrical energy meter with indirect measurement, 5(10)A (, CEM-C31), direct measurement 65 A (CEM-C21) or single-phase energy meter (CEM-C10).

Built-in LCD display (7 digits) with rotating screen system. It can have integrated RS-485 communications, depending on the model. Also features

2 buttons (1 sealable button) for viewing all the measured information.

Other features include:

- MID certification, module B+D (depending on the type)
- Class 1 active energy (Class B, in accordance with MID), Class 2 reactive energy
- Complies with the EN 50470 (MID European standards) or IEC 62052-11 standards (international standards), depending on the type.
- Compact size (CEM-C10: 2 modules, 36 mm, CEM-C21 y CEM-C31: 4 modules, 72 mm)
- Resettable partial meter
- 1 programmable impulse output, in accordance with DIN 43864 (CEM-C10, CEM-C31-T1, CEM-C21-T1 models)
- 1 Digital input for Tariff selection and impulse count (CEM-C31-D, CEM-C21-DS)
- Indicates bad connections on the screen
- Energy storage, even in the case of bad connections

Application

- Redundant meter for verifying the energy allocated by the energy provider.
- Energy consumption report sent to a remote system (PLC/BMS).
- Cost control for achieving a high consumption/unit ratio in industrial processes.
- Display of electrical parameters (V, A, kW, kW-h, PF, etc.), per phase and three-phase.



CEM-C31-485-DS-MID

Energy meter for DIN rail mounting

Code: Q23532.

Specifications

AC power supply

Installation category	CAT III 300 V
Consumption	< 2 W, 10 VA
Frequency	50 ... 60 Hz
Nominal voltage	230 V / 400 V ~ ($\pm 20\%$)

Mechanical characteristics

Size (mm) width x height x depth	70 x 90 x 64 (mm)
Envelope	PC
Fastening	Standardized rail mounting (IEC 60715) (DIN Rail EN-50022)
Weight (kg)	0,256

Environmental characteristics

Protection class	IP 51 (instaled) IP 40 (terminal area)
Relative humidity (without condensation)	5 ... 95 %
Storage temperature	-35 ... +80 °C
Working temperature	-25 ... +70 °C

Current measurement circuit

Consumption	0.3 VA ... 10 A
Reference current (Iref)	5 A
Maximum current	10 A
Minimum current measurement	0.050 A
Transition current	0.25 A

Voltage measurement circuit

Consumption	< 2W , < 10VA (In, Vref)
Nominal frequency	50 / 60 Hz
Nominal voltage	3 x 127/220 ... 3 x 230/400 V ~

Electrical characteristics

Insulation voltage, circuit	4 kV RMS 50 Hz durante 1 min
-----------------------------	------------------------------

Digital inputs

Input impedance	800 Ω (max.)
Type	Self-powered at + 5 Vdc (Vmax = 5.1 V, Imax = 8.5 mA)
Minimum signal width	Ton \geq 30 ms, Toff \geq 30 ms



CEM-C31-485-DS-MID

Energy meter for DIN rail mounting

Code: Q23532.

Standards

Electrical safety, Maximum height (m)

2000



CEM-C31-485-DS-MID

Energy meter for DIN rail mounting

Code: Q23532.

Standards EN 50470-1, EN 50470-3, IEC 62053-21, IEC 62053-23

User interface

LED	2 LED: kWh, 20000 imp/kWh, kvarh, 20000 imp/kvarh
Keyboard	2 Keys
Display type	LCD
Maximum value	999999.9 kWh

Measurement accuracy

Reactive energy measurement (kvarh)	Class 2.0 (IEC 62053-23)
Active energy measurement (kWh)	Class B (EN 50470)

Serial communication

Protocol	Modbus RTU
Technology / Type	RS-485

CEM-C10 and CEM-C21/C31 without built-in RS-485 communications can optionally communicate with CEM-M-ETH and CEM-M-RS485 modules.
 Devices with absolute measurements (Abs). For 2 or 4 quadrants, see the Additional table
 Frequency: 50/60 Hz. Parameters: V, A, kW, kVA, kWh, cos phi

CEM-XXX-TI encoding table - Devices with pulse output (transistor)
 CEM-XXX-DS-Devices with digital input for tariff change and impulse meter



CEM-C31-485-DS-MID

Energy meter for DIN rail mounting

Code: Q23532.

Dimensions

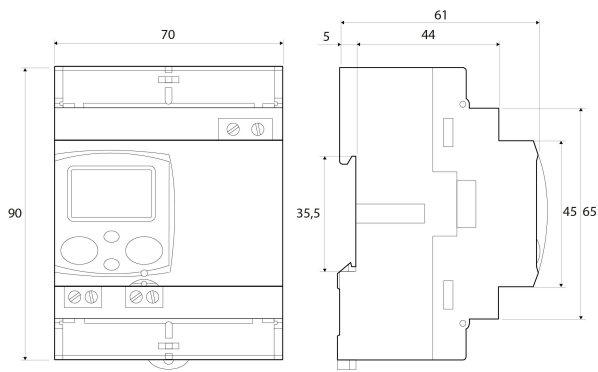

Connections

