



CEM-C31-485-DS

CEM-C31-485-DS, Indirect three-phase energy meter

Code: Q23531.

- > Protocol: Modbus/RTU
- > Módulos: 4
- > Tariff: 2
- > Certification: IEC
- > Communications: RS-485
- > Digital inputs: 1
- > System: Three-phase
- > Measure: Indirect
- > Measurement Range (V): 3 x 57/100...3 x 230/400
- > Measurement Range (A): .../ 5 (10) A
- > Max. Current (A): 10

Description

Three-phase electrical energy meter with indirect measurement, 5(10)A (, CEM-C31), direct measurement 65 A (CEM-C21) or single-phase energy meter (CEM-C10).

Built-in LCD display (7 digits) with rotating screen system. Features built-in RS-485 communications. Also features

2 buttons (1 sealable button) for viewing all the measured information.

Other features include:

- MID certification, module B+D (depending on the type)
- Class 1 active energy (Class B, in accordance with MID), Class 2 reactive energy
- Complies with the EN 50470 (MID European standards) or IEC 62052-11 standards (international standards), depending on the type.
- Compact size (CEM-C10: 2 modules, 36 mm, CEM-C21 y CEM-C31: 4 modules, 72 mm)
- Resettable partial meter
- 1 programmable impulse output, in accordance with DIN 43864 (CEM-C10, CEM-C31-T1, CEM-C21-T1 models)
- 1 Digital input for Tariff selection and impulse count (CEM-C31-D, CEM-C21-DS)
- Indicates bad connections on the screen
- Energy storage, even in the case of bad connections

Application

- Redundant meter for verifying the energy allocated by the energy provider.
- Energy consumption report sent to a remote system (PLC/BMS).
- Cost control for achieving a high consumption/unit ratio in industrial processes.
- Display of electrical parameters (V, A, kW, kW-h, PF, etc.), per phase and three-phase.



CEM-C31-485-DS

Energy meter for DIN rail mounting

Code: Q23531.

Specifications

AC power supply

| | |
|-----------------------|------------------------|
| Installation category | CAT III 300 V |
| Consumption | < 2 W, 10 VA |
| Frequency | 50/60 Hz |
| Nominal voltage | 230 V ~ ($\pm 20\%$) |

Mechanical characteristics

| | |
|----------------------------------|--|
| Size (mm) width x height x depth | 70 x 90 x 64 (mm) |
| Envelope | PC |
| Fastening | Standardized rail mounting (IEC 60715) (DIN Rail EN-50022) |
| Weight (kg) | 0,212 |

Environmental characteristics

| | |
|--|--|
| Protection class | IP 51 (instaled) IP 40 (terminal area) |
| Relative humidity (without condensation) | 5 ... 95 % |
| Storage temperature | -35 ... +80 °C |
| Working temperature | -25 ... +70 °C |

Current measurement circuit

| | |
|-----------------------------|-----------------|
| Consumption | 0.3 VA ... 10 A |
| Reference current (Iref) | 5 A |
| Maximum current | 10 A |
| Minimum current measurement | 0.050 A |
| Transition current | 0.25 A |

Voltage measurement circuit

| | |
|-------------------|---------------------------------|
| Consumption | < 2W , < 10VA (In, Vref) |
| Nominal frequency | 50 / 60 Hz |
| Nominal voltage | 3 x 127/220 ... 3 x 230/400 V ~ |

Electrical characteristics

| | |
|-----------------------------|------------------------------|
| Insulation voltage, circuit | 4 kV RMS 50 Hz durante 1 min |
|-----------------------------|------------------------------|

Digital inputs

| | |
|----------------------|---|
| Input impedance | 800 Ω (max.) |
| Type | Self-powered at + 5 Vdc (Vmax = 5.1 V, Imax = 8.5 mA) |
| Minimum signal width | Ton \geq 30 ms, Toff \geq 30 ms |



CEM-C31-485-DS

Energy meter for DIN rail mounting

Code: Q23531.

Standards

Electrical safety, Maximum height (m)

2000



CEM-C31-485-DS

Energy meter for DIN rail mounting

Code: Q23531.

Standards

EN 50470-1, EN 50470-3, IEC 62053-21, IEC 62053-23

User interface

| | |
|---------------|--|
| LED | 2 LED: kWh, 20000 imp/kW, kvarh, 20000 imp/kvarh |
| Keyboard | 2 Keys |
| Display type | LCD |
| Maximum value | 999999.9 kWh |

Measurement accuracy

| | |
|-------------------------------------|--------------------------|
| Reactive energy measurement (kvarh) | Class 2.0 (IEC 62053-23) |
| Active energy measurement (kWh) | Class B (EN 50470) |

Serial communication

| | |
|-------------------|------------|
| Protocol | Modbus RTU |
| Technology / Type | RS-485 |

CEM-C

Energy meter

| CODE | TYPE | Measurement Range (V) | Measurement Range (A) | Communications | Protocol | Transistor output | Digital inputs | Tariff | Certification |
|-----------------------------|--------------------|---------------------------|-----------------------|----------------|------------|-------------------|----------------|--------|---------------|
| Direct three-phase | | | | | | | | | |
| Q22411. | CEM-C21-T1 | 3 x 127/220...3 x 230/400 | 5 (65) A | - | - | 1 | - | 1 | IEC |
| Q22421. | CEM-C21-485-T1 | 3 x 127/220...3 x 230/400 | 5 (65) A | RS-485 | Modbus/RTU | 1 | - | 1 | IEC |
| Q22431. | CEM-C21-485-DS | 3 x 127/220...3 x 230/400 | 5 (65) A | RS-485 | Modbus/RTU | 0 | 1 | 2 | IEC |
| Q22412. | CEM-C21-T1-MID | 3 x 127/220...3 x 230/400 | 5 (65) A | - | - | 1 | - | 1 | MID |
| Q22422. | CEM-C21-485-T1-MID | 3 x 127/220...3 x 230/400 | 5 (65) A | RS-485 | Modbus/RTU | 1 | - | 1 | MID |
| Q22432. | CEM-C21-485-DS-MID | 3 x 127/220...3 x 230/400 | 5 (65) A | RS-485 | Modbus/RTU | 0 | 1 | 2 | MID |
| Indirect three-phase | | | | | | | | | |
| Q23511. | CEM-C31-T1 | 3 x 57/100...3 x 230/400 | .../ 5 (10) A | - | - | 1 | - | 1 | IEC |
| Q23521. | CEM-C31-485-T1 | 3 x 57/100...3 x 230/400 | .../ 5 (10) A | RS-485 | Modbus/RTU | 1 | - | 1 | IEC |
| Q23531. | CEM-C31-485-DS | 3 x 57/100...3 x 230/400 | .../ 5 (10) A | RS-485 | Modbus/RTU | 0 | 1 | 2 | IEC |
| Q23512. | CEM-C31-T1-MID | 3 x 57/100...3 x 230/400 | .../ 5 (10) A | - | - | 1 | - | 1 | MID |
| Q23522. | CEM-C31-485-T1-MID | 3 x 57/100...3 x 230/400 | .../ 5 (10) A | RS-485 | Modbus/RTU | 1 | - | 1 | MID |
| Q23532. | CEM-C31-485-DS-MID | 3 x 57/100...3 x 230/400 | .../ 5 (10) A | RS-485 | Modbus/RTU | 0 | 1 | 2 | MID |

CEM-C10 and CEM-C21/C31 without built-in RS-485 communications can optionally communicate with CEM-M-ETH and CEM-M-RS485 modules.

Devices with absolute measurements (Abs). For 2 or 4 quadrants, see the Additional table

Frequency: 50/60 Hz. Parameters: V, A, kW, kVA, kWh, cos phi

CEM-XXX-T1 encoding table - Devices with pulse output (transistor)

CEM-XXX-DS-Devices with digital input for tariff change and impulse meter



CEM-C31-485-DS

Energy meter for DIN rail mounting

Code: Q23531.

Dimensions

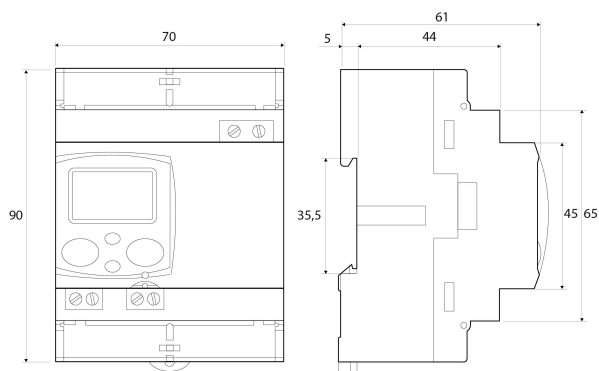

Connections

