



IDA-EV-63-30

IDA-EV-63-30, Residual current relay Type A

Code: P17322.

- > Poles: 4
- > In (A): 63 A
- > Sensitivity: 30 mA + 6 mAdc
- > Mounting: DIN rail

Description

IDA-EV is a 6mA_{dc} type-A RCCB with monitoring for use in electric vehicle chargers. Compact RCCB that provides residual current protection, with a sensitivity of 30 mA and 6 mA_{dc} monitoring for use in electric vehicle charging stations. Available in 40 and 63 A nominal current gauges, for three-phase and single-phase connections. It guarantees adequate protection at electric vehicle charging points, in accordance with the **IEC 62955** standard.

Application

Device specifically designed to provide residual current protection of electric vehicle charging stations.



IDA-EV-63-30

Type A RCCB with 6 mAdc monitoring

Code: P17322.

Specifications

AC power supply

Frequency	50/60 Hz
Nominal voltage	400 V ~ / 415 V ~

Electrical characteristics

Mechanical life	10000 operations
Electrical lifetime	2000 cycles

Mechanical characteristics

Size (mm) width x height x depth	72 x 87.5 x 68 (mm)
Envelope	Self-extinguishing V0 plastic
Fastening	DIN rail (EN 60715, EN 50022)
Weight (kg)	0,38

Environmental characteristics

Protection class	IP 20
Relative humidity (without condensation)	5 ... 95%
Storage temperature	-40 ... +85 °c
Working temperature	-25 ... +65 °C

Current measurement circuit

Nominal current (In)	63 A
----------------------	------

Standards

Electrical safety, Maximum height (m)	2000
Electrical safety, Installation category	CAT III, IEC 61010
Standards	IEC 61008, IEC 62956

Electrical safety

Insulation	Double-insulated electric shock protection class II (IEC 61010-1)
------------	---

Differential protection

Type	Type A+6mAdc
Sensitivity (IΔn), A	0,03
Delay time (tΔ)	Instantaneous or General (IEC 61008-1)

IDA-EV

RCCB with 6 mAdc supervision type A



IDA-EV-63-30

Type A RCCB with 6 mAdc monitoring

Code: P17322.

CODE	TYPE	In (A)	Mounting	Poles	Sensitivity
P17321.	IDA-EV-40-30	40 A	DIN rail	4	30 mA + 6 mAdc
P17322.	IDA-EV-63-30	63 A	DIN rail	4	30 mA + 6 mAdc



IDA-EV-63-30

Type A RCCB with 6 mAdc monitoring

Code: P17322.

Dimensions

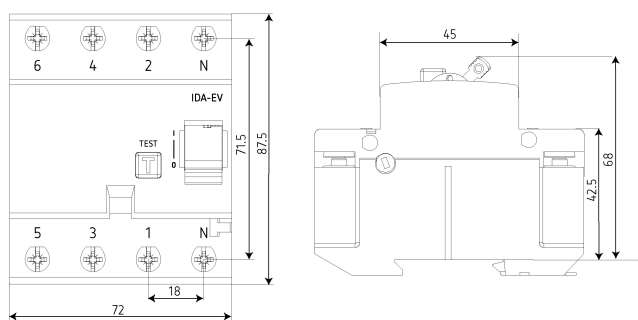

Connections

IMPORTANTE: Compruebe qué identificación de bornes tiene su dispositivo a instalar. Asegúrese de conectar los cables correctamente conforme a la identificación de los bornes.

IMPORTANT: Check the terminal identification of your device to be installed. Be sure to connect the wires correctly according to the terminal identification.

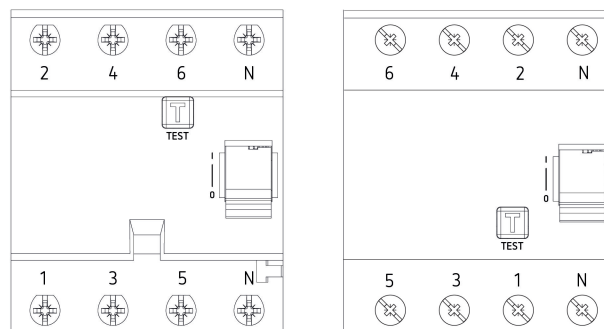

Consulte la guía correspondiente a su equipo aquí:
Please refer to the manual for your equipment here:

