



WGB-35-TB300S

WGB-35-TB300S, Residual current relay

Code: P16131.

- > Usefull diam.(mm): 35
- > Delay: SEL
- > Sensitivity: 300 mA

Description

Residual current protection device for the protection of people and property against fault currents, such as:

- Sinusoidal alternating currents and pulsating residual direct currents..
- Sinusoidal alternating currents, up to 1 kHz.
- Direct currents

For installations up to 125 A and sensitivities of 30 or 300 mA. INSTantaneous/SElective activation of the circuit breaker, circuit breaker with fast trigger coil or contactor.

Application

All electrical installations where process continuity is critical and protection of persons (30 mA) and machines (300 mA) is required, with non-adjustable immediate or SElective activation.

- Computer systems (UPS systems)
- Speed drives
- Photovoltaic installations
- Electric Vehicle Charging systems



WGB-35-TB300S

Transformer with built-in residual current relay (Class B)

Code: P16131.

Specifications

AC power supply

Consumption	6 VA
Frequency	50 ... 60 Hz
Nominal voltage	230V ~ ± 20%

Mechanical characteristics

Size (mm) width x height x depth	166 x 79 x 48 (mm)
Envelope	Polycarbonate V0
Weight (kg)	0,25

Environmental characteristics

Protection class	IP 40
Relative humidity (without condensation)	5 ... 95 %
Storage temperature	-15 ... +55 °C
Working temperature	-10 ... +50 °C

Specific technical characteristics of current sensors

Trigger point setting	85 % of nominal earth leakage current
Harmonic filtering	2nd order filter (Fc = 400 Hz)
Waveform measurements	2nd order filter (Fc = 400 Hz)
Inner diameter Ø (mm)	35 mm
Trip point tolerance	± 15 %

Current measurement circuit

Nominal current (In)	125 A
----------------------	-------

Standards

Electrical safety, Maximum height (m)	2000
Standards	IEC 60755, IEC 62423, IEC 60947-2-M

User interface

LED	2 LED
Keyboard	2 keys

Digital relay outputs

AC11 Ie/Ue	6 A / 250 V
Electrical life	30 x 10 ³ (250Vca / 5A)
Mechanical life	5 x 10 ⁶



WGB-35-TB300S

Transformer with built-in residual current relay (Class B)

Code: P16131.

Maximum switching capacity 1500 W (AC1)

Differential protection

Type	Type B
Sensitivity ($I_{\Delta n}$), A	0,3
Delay time (t_{Δ})	INS/SEL
Transformer	Built-in earth leakage transformer, 35 mm

Protection

LED indication	Power supply voltage Earth leakage tripping
Circuit breaker type	Magnet with fast trigger coil or contactor

WGB-35-TB

Type B relay with built-in residual current transformer

CODE	TYPE	Inner diameter (mm)	Sensitivity	Delay
P16111.	WGB-35-TB30	35	30 mA	INS
P16121.	WGB-35-TB300	35	300 mA	INS
P16131.	WGB-35-TB300S	35	300 mA	SEL

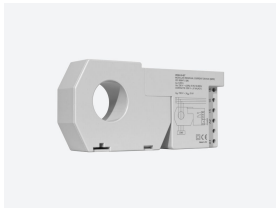

WGB-35-TB300S

Transformer with built-in residual current relay (Class B)

Code: P16131.

Dimensions

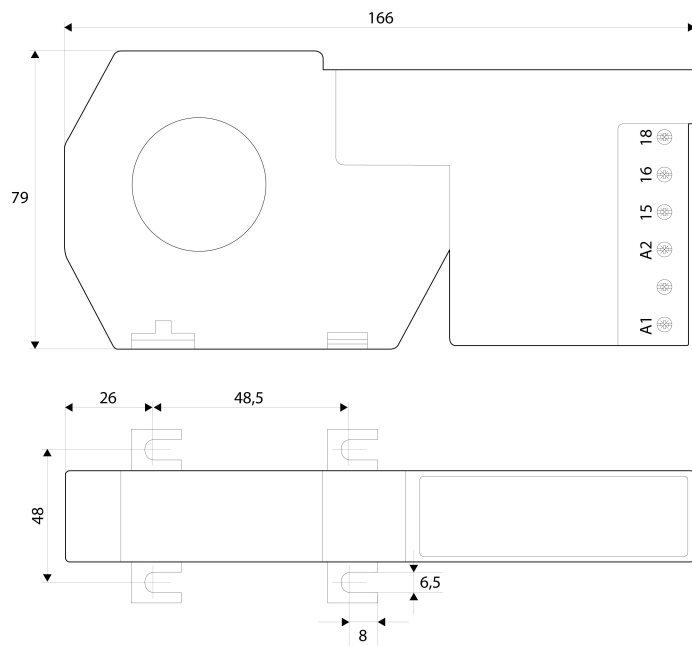

Connections

