



## CVM-C11-FLEX+3 MFC-FLEX-80

Code: M58562.

### Description

The **CVM-C11** is a power analyzer for a panel (96 x 96 mm) with power logging. Ideal for analyzing electrical and consumption quality variables, such as THD% for voltage and current, as well as individual harmonics for each phase up to the 31st. The inclusion of neutral current measurement lets users detect any imbalance, as well as detect overloads in the neutral conductor. Compact and versatile with measurements in 4 quadrants (consumption and generation), suitable for medium- and low-voltage installations.

Display and interface characteristics:

- User-defined parameter display.
- Backlit screen
- On-screen graphic display of instantaneous active power
- On-screen graphic display of all quadrants (Q1, Q2, Q3, Q4).
- On-screen numerical indication of the value of  $\cos \varphi$  or PF.
- On-screen indication of the status of outputs, inputs and/or active tariff.
- LED alarm indicator
- Costs, kg of CO<sub>2</sub> emitted and operating time per tariff

### Application

- Discrimination of power consumption into three tariffs. Ideal for determining consumption during three different work shifts or from three different energy sources (grid, generator and photovoltaic generation), using the digital inputs.
- Generation of an impulse signal related to cost, kg of CO<sub>2</sub> emitted or proportional to energy consumption or generation.
- Alarm control (2 relay outputs + 2 digital outputs) for any instantaneous parameter, whether measured or calculated. Adjustable based on maximum/minimum value, hysteresis (%), NO/NC, connection/disconnection delay and interlocks.



## CVM-C11-FLEX+3 MFC-FLEX-80

Power analyzer for panel

Code: M58562.

### Specifications

#### AC power supply

Installation category	CAT III 300 V
Consumption	2,5 ... 5,5 VA
Frequency	50 ... 60 Hz
Nominal voltage	100 ... 270 V ~ ± 10%

#### DC power supply

Installation category	CAT III 300 V
Nominal voltage	100 ... 270 Vdc ± 10%

#### Mechanical characteristics

Size (mm) width x height x depth	96 x 96 x 67.2 (mm)
Envelope	Self-extinguishing V0 plastic
Fastening	Panel
Weight (kg)	1,01

#### Environmental characteristics

Protection class	IP 54 (Front), IK 08
Relative humidity (without condensation)	5 ... 95%
Storage temperature	-25 ...+75 °C
Working temperature	-25 ...+70 °C

#### Current measurement circuit

Installation category	CAT III 300 V
Nominal current (In)	100 mV/kA (without/sin sensors MFC-FLEX)
Minimum current measurement	0.2 mV

#### Voltage measurement circuit

Installation category	CAT III 300 V
Input impedance	> 1.7 MΩ
Frequency measuring range	45 ... 65 Hz
Nominal voltage	230V Ph-N, 380V Ph-Ph
Minimum measurement voltage (Vstart)	10 V ~
Maximum value	300 VF-N / 520 VF-F

#### User interface

Keyboard	3 keys
Display type	LCD Custom COG



## CVM-C11-FLEX+3 MFC-FLEX-80

Power analyzer for panel

Code: M58562.

### Digital inputs

Input/output insulation	2000 V
Quantity	2
Type	NPN

### Digital relay outputs

Electrical life (at maximum load)	60x10 <sup>3</sup> cycles
Mechanical life	10x10 <sup>6</sup> cycles
Maximum switching capacity	625 VA / 75 W (AC1)

### Digital transistor outputs

Pulse width	30 ms a 400 ms (Programmable)
Quantity	2
Type	NPN
Maximum frequency	16 imp / s
Maximum current	50 mA
Maximum voltage	24 Vdc

### Measurement accuracy

Phase current measurement	0.5% (10 ... 300% In), without/sin MFC-FLEX
Reactive power measurement (kvar)	2% without/sin MFC-FLEX
Active power measurement (kW)	1% without/sin MFC-FLEX
Power factor measurement	0.5 %
Phase voltage measurement	0.2% (5 ...120% Un)

### Serial communication

Protocol	ModBus RTU BACnet
Technology / Type	RS-485

### CVM-C11

Power analyzer, panel mounted 96 x96

CODE	TYPE	Measuring Channels	Input current	Transistor output	N° relays	Digital inputs	Communications	Protocol	Harmonics	Power supply
M58531.	CVM-C11-ITF-IN-ETH-ICT2	4	.../5 A   .../1 A	2	2	2	Ethernet	Modbus/TCP   BACnet	31	100...270 Vac/dc
M58541.	CVM-C11-ITF-IN-485-ICT2	4	.../5 A   .../1 A	2	2	2	RS-485	Modbus/RTU   BACnet	31	100...270 Vac/dc
M58581.	CVM-C11-MC-IN-485-ICT2	4	.../250 mA	2	2	2	RS-485	Modbus/RTU   BACnet	31	100...270 Vac/dc
M58561.	CVM-C11-FLEX-IN-485-ICT2	4	100 mV/kA	2	2	2	RS-485	Modbus/RTU   BACnet	31	100...270 Vac/dc



## CVM-C11-FLEX+3 MFC-FLEX-80

Power analyzer for panel

Code: M58562.

CODE	TYPE	Measuring Channels	Input current	Transistor output	N° relays	Digital inputs	Communications	Protocol	Harmonics	Power supply
Kits										
M58562.	CVM-C11-FLEX+3 MFC-FLEX-80									
M58563.	CVM-C11-FLEX+3 MFC-FLEX-125									
M58564.	CVM-C11-FLEX+4 MFC-FLEX-80									
M58565.	CVM-C11-FLEX+4 MFC-FLEX-125									



# CVM-C11-FLEX+3 MFC-FLEX-80

Power analyzer for panel

Code: M58562.

## Dimensions

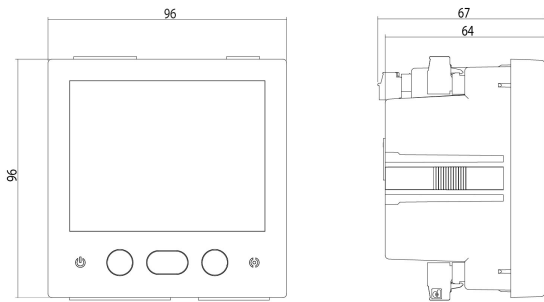

## Connections

### Red Trifásica 4 hilos 4-wire-three-phase network

