



CVM-D41 DC V

CVM-D41 DC V, Digital multimeter DIN rail, 2 output relays

Code: M5663A. [CONSULTAR DISPONIBILIDAD](#)

- > Protocol: Modbus/RTU
- > Módulos: 6
- > IP: 54
- > Communications: RS-485
- > N° relays: 2
- > Digital inputs: 2
- > Analog output: 1 (0 ... 10V)
- > System: DC (Shunt)
- > Measurement Range (V): $\pm 150 / 300 / 600 / 1000 / 1500$ Vdc
- > Measurement Range (A): 50 / 60 / 75 / 100 / 150 / 200 / 250 / 300 / 400 / 600 mA
- > Parameters: V/A/kW/kWh dc
- > Mounting: DIN Rail

Description

The **CVM-D41 DC** is a digital power analyzer for installing on a DIN rail. Its screens are operated using buttons to display different electrical parameters in a DC network of up to 1500 VDC, such as voltage, current, power and energy (A·h).

This analyzer has the following key features:

- DIN rail installation.
- DC voltage measurement up to 1500VDC CATIII
- Shunt current measurement
- 2 digital inputs + 2 relay outputs + 1 analogue output (0/4...20 mA) or (0 / 2 ... 10 Vdc), depending on the model
- LED status indicator
- RS-485 communications (Modbus/RTU)
- Configuration via Power Studio SCADA

Application

Measurement and management of installations with a DC power supply:

- Industrial Applications
- Electric vehicle charging points
- Self-supply systems
- Solar photovoltaic Installations
- HVAC
- Industrial process control



CVM-D41 DC V

Digital instruments: Programmable DC measurement Central

Code: M5663A.

Specifications

AC power supply

Installation category	CAT III 300V
Consumption	6 ... 18 VA
Frequency	50/60 Hz
Nominal voltage	100...270 V ~

DC power supply

Installation category	CAT III 300 V
Consumption	1.3 ... 2 W
Nominal voltage	100...270 Vdc

Mechanical characteristics

Size (mm) width x height x depth	108 x 117.43 x 74 (mm)
Weight (kg)	0,7

Environmental characteristics

Relative humidity (without condensation)	≤ 93 %
Storage temperature	-25 ... +70 °C
Working temperature	-25 ... +70 °C

Current measurement circuit

Installation category	CAT III 1500 V
Consumption	< 1 VA
Nominal current (In)	Shunt: 50 / 60 / 75 / 100 / 150 / 200 / 250 / 300 / 400 / 600 mV
Allowable overload	1.2 In continuous (max.1500 Vdc)

Voltage measurement circuit

Installation category	CAT III 1500 V
Consumption	< 1 VA
Nominal voltage	± 150 / 300 / 600 / 1000 / 1500 Vdc
Maximum permanent measurement voltage	1.2 Un continuous

Standards

Electrical safety, Maximum height (m)	2000
Electrical safety, Contamination level/class	Pollution resistance 2
Standards	IEC 61000-4-2, IEC 61000-4-3, IEC 61000-4-4, IEC 61000-4-5, IEC 61000-4-6, IEC 61000-4-8, IEC 61000-4-11, IEC 61010-1, IEC 61326-1, IEC 61010-2-030

User interface



CVM-D41 DC V

Digital instruments: Programmable DC measurement Central

Code: M5663A.

Display type	LCD 5 digits
Digital inputs	
Input/output insulation	4000 V ~
Quantity	2
Type	Potential-free contact
Maximum short-circuit current	3.3 mA dc
Maximum open circuit voltage	17 V dc
Analogue outputs	
Quantity	1
Linearity	0.5 %
Current mode: maximum load resistance	350 Ω
Voltage mode: nominal output range	0 / 2 ... 10 Vdc
Maximum internal voltage	17 V dc
Digital relay outputs	
Quantity	2
Maximum current	2.5 A
Electrical life	1 x 10 ⁵ (250 V~ / 5A)
Maximum switching capacity	625 VA
Measurement accuracy	
Phase current measurement	Class 0.5
Active energy measurement (kWh)	Class 1
Active power measurement (kW)	Class 1
Phase voltage measurement	Class 0.5
Serial communication	
Protocol	ModBus RTU
Technology / Type	RS-485

CVM-D41 DC

DC power analyzer

CODE	TYPE	System	Measurement Range (V)	Measurement Range (A)	N° relays	Digital inputs	Analog output	Módulos	Protocol
Multimeter									
M56638.	CVM-D41 DC mA DC (Shunt)		± 150 / 300 / 600 / 1000 / 1500 Vdc	50 / 60 / 75 / 100 / 150 / 200 / 250 / 300 / 400 / 600 mV	2	2	1 (20 mA)	6	Modbus/RTU
M566380040000	CVM-D41 DC mA DC (Shunt)		± 150 / 300 / 600 / 1000 / 1500 Vdc	50 / 60 / 75 / 100 / 150 / 200 / 250 / 300 / 400 / 600 mV	2	2	1 (20 mA)	6	Modbus/RTU



CVM-D41 DC V

Digital instruments: Programmable DC measurement Central

Code: M5663A.



CVM-D41 DC V

Digital instruments: Programmable DC measurement Central

Code: M5663A.

Dimensions

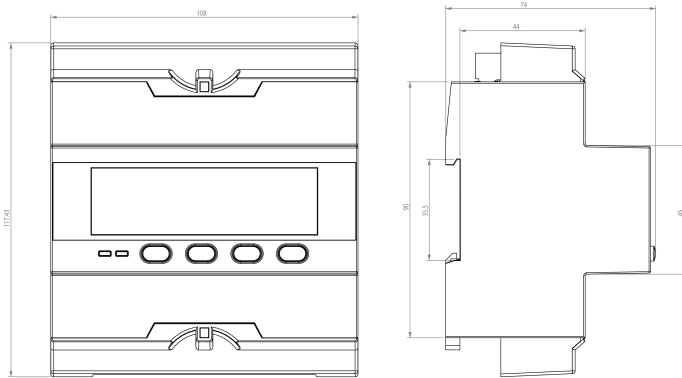

Connections

