



## CVM-D50-ITF

CVM-D50-ITF, Three-phase power analyser with DIN-rail memory

Code: M56570.

- > Protocol: Modbus/TCP
- > Memory: Yes
- > Communications: Ethernet | Wi-Fi
- > Harmonics: 31
- > Power supply: 90...264 Vac/Vdc
- > Input current: .../5 A | .../1 A
- > Mounting: DIN rail

### Description

Three-phase power analyzer (balanced and unbalanced) for assembly on DIN rail, very small, with 4-quadrant measurements and integrated memory for data logging.

Main features include:

- Current measurement (depending on model) .../5 or.../1 A or.../250 mA or Rogowski-type sensors.
- Wi-Fi and Ethernet communications (Modbus TCP/IP).
- Integrated memory.
- With web Server to view, configure and download data.
- Compatible with the MyConfig app.
- Sealable with terminal cover.
- Display of THD% and up to the 31st harmonic (V, A).
- DIN rail format just 3 modules wide.
- High-contrast backlit display.
- 72 x 72 mm panel mount with front adapter

### Application

- Control application in distribution panels and low- and medium-voltage connections where an analyzer has to be installed on the DIN rail due to space constraints.
- Alarm control: Maximum value, minimum, delay and programmable interlocking.
- Logging of active or capacitive and inductive reactive energy.
- Capture and storage of instantaneous, maximum and minimum data of the electrical parameters measured.



## CVM-D50-ITF

Three-phase power analyser with DIN-rail memory

Code: M56570.

### Specifications

#### AC power supply

Installation category	CAT III 300 V
Consumption	2,7 ... 4 VA
Frequency	50...60 Hz
Nominal voltage	100 ... 240 V~ ± 10 %

#### DC power supply

Consumption	1,8 ... 2 W
Nominal voltage	100 ... 240 Vd.c. ± 10 %

#### Mechanical characteristics

Size (mm) width x height x depth	52.5 x 118 x 74 (mm)
Envelope	Self-extinguishing V0 plastic
Fastening	DIN rail
Weight (kg)	0,25

#### Environmental characteristics

Protection class	IP 30 / Front: IP 40 IK08
Relative humidity (without condensation)	5...95%
Storage temperature	-30 ... +80 °C
Working temperature	-10 ... +50 °C

#### Current measurement circuit

Installation category	CAT III 300 V
Nominal current (In)	.../5 A or .../1 A
Phase current measuring range	2...120% In
Maximum input current consumption	0,9 VA
Minimum current measurement	10 mA

#### Voltage measurement circuit

Installation category	CAT III 300 V
Input impedance	400 kΩ
Frequency measuring range	45...65 Hz
Nominal voltage	230V Ph-N, 400V Ph-Ph
Minimum measurement voltage (Vstart)	11,5 V Ph-N

#### Communication Network

Protocol	Modbus TCP - Web server
Technology / Interface	Ethernet



## CVM-D50-ITF

Three-phase power analyser with DIN-rail memory

Code: M56570.

### Standards

Electrical safety, Maximum height (m)	2000
Electrical safety, Contamination level/class	2
Standards	IEC/EN 61010-1; IEC/EN 61010-2-030; UNE-EN 55016-2-1; UNE-EN 61000-4-2; UNE-EN 61000-4-20; UNE-EN 61000-4-4; UNE-EN 61000-4-5; UNE-EN 61000-4-6; UNE-EN 61000-4-8; UNE-EN IEC 61000-4-11; UNE-EN 61000-4-3; ETSI-EN 301 489-1 Ver. 2.1.1; ETSI-EN 301 489-17 Ver. 3.1.1; UNE-EN 60068-2-1; UNE-EN 60068-2-2:2008; UNE-EN 60068-2-78; IEC 61557-12; EN 18031-1

### User interface

Keyboard	3 keys
Display type	LCD Custom COG

### Measurement accuracy

Frequency measurement	0,50%
Phase current measurement	0,5% ± 1 digit (2 ... 120% In)
Active power measurement (kW)	0.5 % ±2 digit
Phase voltage measurement	0.5% ± 1 digit (5 ... 120 % Un)

### Wireless communication

Band	Wi-Fi (2.4 ... 2.5 GHz.)
Technology / Type	Wi-Fi, IEEE 802.11 b/g, IEEE 802.11 n (Up 150 Mbps)

### CVM-D50

Din rail three-phase power analyser with memory

CODE	TYPE	Power supply	Input current	Communications	Protocol	Harmonics	Memory
M56570.	CVM-D50-ITF	90...264 Vac/Vdc	.../5 A   .../1 A	Ethernet   Wi-Fi	Modbus/TCP	31	Yes
M56580.	CVM-D50-MC	90...264 Vac/Vdc	.../250 mA	Ethernet   Wi-Fi	Modbus/TCP	31	Yes
M56590.	CVM-D50-FLEX	90...264 Vac/Vdc	Rogowski	Ethernet   Wi-Fi	Modbus/TCP	31	Yes

It has a free configuration App (MyConfig) and WebServer for configuration, visualization and data download



# CVM-D50-ITF

Three-phase power analyser with DIN-rail memory

Code: M56570.

## Dimensions

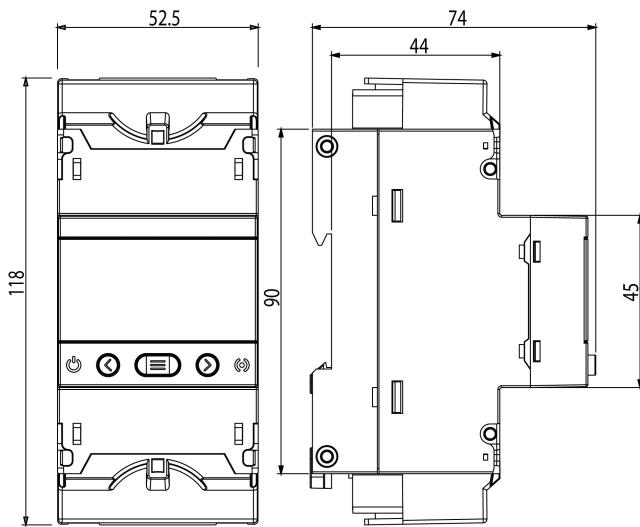

## Connections

### Red trifásica a 3 hilos / 3-wire three-phase network (ARON)

