

CV-D Out1,3

CV-D Out1,3, Transducer Vdc

Code: M25061.

- > Output type: 1, 3
- > Analog output: 0...20mA
- > Measure: 10 Vdc
- > Paramètre: Vdc

Description

The **CV-D** transducers, convert D.C voltage to D.C process indicator signal, and it can be used for galvanic separation between the input and output circuits.

The analog output is directly proportional to the input signal.



CV-D Out1,3

DC Voltage transducer

Code: M25061.

Specifications

AC power supply

Consumption	2,5 VA
Frequency	40...90 Hz
Nominal voltage	24/115/230/400 Vca (-15...+20%)

Mechanical characteristics

Size (mm) width x height x depth	40 x 72 x 110 (mm)
Weight (kg)	0,29

Environmental characteristics

Protection class	IP 20 (Terminals) IP 40 (case)
Storage temperature	-40...+70 °C
Working temperature	-10...+55 °C

Voltage measurement circuit

Input impedance	10000 Ω/V
Voltage measuring range	0...120 % Vn
Nominal voltage	10 mV...500 Vca
Maximum permanent measurement voltage	150 % Vn

Standards

Electrical safety, Maximum height (m)	2000
Standards	IEC 529, IEC 688, IEC 801, EN 50081-2, EN 50082-2, IEC 1010

Analogue inputs

Load impedance in current	< 500 Ω
Ripple (effective RMS value)	< 0,5 %
Load impedance in voltage	> 500 Ω
Response time	< 100 ms (0...99 % Vn)

Analogue outputs

Current mode, nominal range	0...20 mA
Displaced output	0,2...2 V / 2...10 V / 4...20 mA
Voltage mode: nominal output range	0...5, 10 Vac

Measurement accuracy

Phase current measurement	0,2 % FS
---------------------------	----------



CV-D Out1,3

DC Voltage transducer

Code: M25061.

CV-D

DC Transducer Voltage

CODE	TYPE	Output type	Analog output	Measure	Paramètre
DC Voltage. Auxiliary supply 230 V, 40...90 Hz, Accuracy: $\pm 0,5$ % reading					
M25061.	CV-D Out1,3	1, 3	0...20mA	10 Vdc	Vdc
M25062.	CV-D Out2	2	4...20mA	10 Vdc	Vdc

-AP type: Accuracy: $\pm 0,5$ % reading, 40...90 Hz. External auxiliary supply not required. Specify: Zero value, full scale and output type.

For other values, see coding table on following pages



CV-D Out1,3

DC Voltage transducer

Code: M25061.

Dimensions

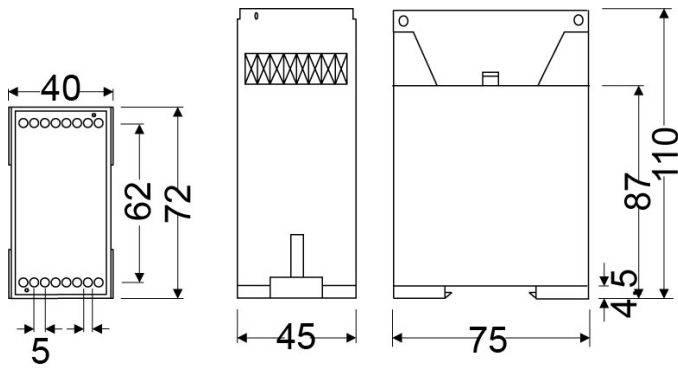

Connections

