



CV-A Out1

CV-A Out1, Transducer Vac.

Code: M25031. [CONSULTAR DISPONIBILIDAD](#)

- > Output type: 1
- > Analog output: 0...20mA
- > Measure: 300 Vac
- > Paramètre: V ~

Description

The **CV-A** transducers, convert A.C voltage to D.C process indicator signal.

The analog output is directly proportional to the input signal, calibrated as a RMS with sinus signal of 50 Hz.



CV-A Out1

A.C. Voltage transducer

Code: M25031.

Specifications

AC power supply, insulation

Pulse test (kV)	4 kV (1,2/50µs)
Test voltage (kV)	3 kV RMS 50 Hz 1min

AC power supply

Consumption	2,5 VA
Frequency	40...90 Hz
Nominal voltage	230 Vca

Mechanical characteristics

Size (mm) width x height x depth	40 x 72 x 110 (mm)
Weight (kg)	0,262

Environmental characteristics

Protection class	IP 20 (Terminals) IP 40 (case)
Storage temperature	-40...+70 °C
Working temperature	-10...+55 °C

Voltage measurement circuit

Input impedance	3000 Ω/V
Frequency measuring range	45...65 Hz
Voltage measuring range	0...150 % Vn
Nominal voltage	0...660 Vca
Maximum permanent measurement voltage	1000 V

Standards

Electrical safety, Maximum height (m)	2000
Standards	IEC 529, IEC 688, IEC 801, IEC 1010

Analogue inputs

Load impedance in current	< 500 Ω
Ripple (effective RMS value)	< 0,5 %
Load impedance in voltage	> 500 Ω
Response time	< 300 ms (0...99 % Vn)

Analogue outputs

Current mode, nominal range	0...20 mA
Displaced output	0,2...2 V / 2...10 V / 4...20 mA
Voltage mode: nominal output range	0...5, 10 Vac



CV-A Out1

A.C. Voltage transducer

Code: M25031.

Measurement accuracy

Phase current measurement 0,2 % FS

CV-A

AC Transducer Voltage

CODE	TYPE	Output type	Analog output	Measure	Paramètre
AC Voltage. Accuracy: $\pm 0,2$ % reading, 40...90 Hz					
M25032.	CV-A Out2	2	4...20mA	300 Vac	V ~

-AP type: Accuracy: $\pm 0,5$ % reading, 40...90 Hz. External auxiliary supply not required. Specify: Zero value, full scale and output type.

For other values, see coding table on following pages



CV-A Out1

A.C. Voltage transducer

Code: M25031.

Dimensions

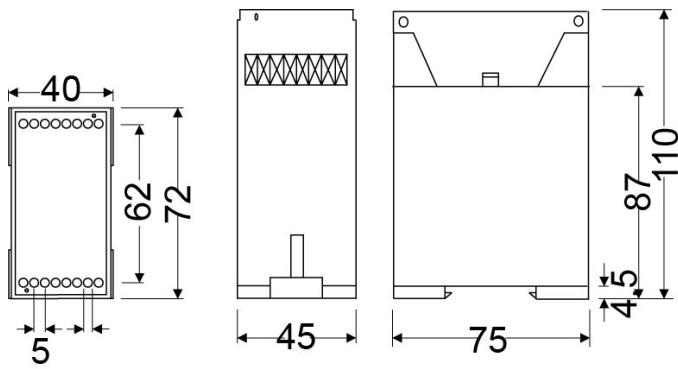

Connections

