



## DHC-96 CPM-HS

DHC-96 CPM-HS, digital multimeter 96 x 48, 2 output relays

Code: M223B8. **CONSULTAR DISPONIBILIDAD**

- > Protocol: Modbus/RTU
- > IP: 54
- > Communications: RS-485
- > N° relays: 2
- > Digital inputs: 2
- > Analog output: 1 (20 mA)
- > System: DC (Hall)
- > Measurement Range (V):  $\pm 150 / 300 / 600$  Vdc
- > Measurement Range (A): 4 Vdc
- > Paramètre: V/A/kW/kWh dc
- > Mounting: Pannel
- > Modules: 96 x 48

### Description

Panel-mounted digital instruments that display the value of an electrical variable measured or proportional value of a process signal on its screen (depending on the model). Designed to supervise, regulate and control units with the use of relay outputs that are built in the unit.

The **DHC-96** series displays the value of an electrical variable measured or proportional value of a process signal on its screen (depending on the model). The unit displays the electrical parameters of a single-phase installation, depending on the model, such as the voltage, current, etc. In DC systems, the unit can measure the voltage, current, frequency and other variables associated with industrial processes. The AC models take the measurements in true RMS (TRMS).

All models in this range have the following features:

- Universal power supply at 80...270 V<sub>ac/dc</sub> (DHC-96-CPM: 100...270 Vac/dc) and optional power supply at 16 ... 36 V<sub>dc</sub> (DHC-96-CPM: 20...60 Vdc)
- IP 54 protection degree on the front panel
- High measurement accuracy
- Programmable measuring input
- Alarm delays and interlockings
- Galvanic insulation between external circuits
- Self-configurable decimal point
- Installed on 96 x 49 mm panels

### Application

These digital instruments have many different applications and can be used in:

- Industrial applications
- Air conditioning units
- Solar photovoltaic energy installations
- Industrial process control systems



## DHC-96 CPM-HS

Digital instruments: Programmable DC measurement Central

Code: M223B8.

### Specifications

#### AC power supply

Installation category	CAT III 300V
Consumption	6 ... 18 VA
Frequency	50/60 Hz
Nominal voltage	100...270 V ~

#### DC power supply

Installation category	CAT III 300 V
Consumption	1.3 ... 2 W
Nominal voltage	100...270 Vdc

#### Mechanical characteristics

Size (mm) width x height x depth	96 x 49 x 107.8 (mm)
Weight (kg)	0,235

#### Environmental characteristics

Relative humidity (without condensation)	≤ 93 %
------------------------------------------	--------

#### Current measurement circuit

Installation category	CAT III 600 V
Consumption	< 1 VA
Nominal current (In)	Sensorhalle ± 4 V
Allowable overload	1.2 In continuous

#### Voltage measurement circuit

Installation category	CAT III 600 V
Consumption	< 1 VA
Input impedance	> 1 MΩ
Nominal voltage	± 150 / 300 / 600 Vdc
Maximum permanent measurement voltage	1.2 Un continuous

#### Standards

Electrical safety, Maximum height (m)	2000
Electrical safety, Installation category	CAT III 300 V
Standards	IEC 61000-4-2, IEC 61000-4-3, IEC 61000-4-4, IEC 61000-4-5, IEC 61000-4-6, IEC 61000-4-8, IEC 61000-4-11

#### User interface

Keyboard	4 keys
----------	--------



## DHC-96 CPM-HS

Digital instruments: Programmable DC measurement Central

Code: M223B8.

Display type	LCD 5 digits
<b>Digital inputs</b>	
Input/output insulation	2000 V ~
Quantity	2
Type	Potential-free contact
Maximum short-circuit current	3.3 mA dc
Maximum open circuit voltage	17 V dc
<b>Analogue outputs</b>	
Quantity	1
Linearity	0.5 %
Current mode: maximum load resistance	350 $\Omega$
Maximum internal voltage	17 V dc
<b>Digital relay outputs</b>	
Quantity	2
Maximum current	2.5 A
Electrical life	1 x 10 <sup>5</sup>
Maximum switching capacity	625 VA
<b>Measurement accuracy</b>	
Phase current measurement	Class 0.5
Active energy measurement (kWh)	Class 1
Active power measurement (kW)	Class 1
Phase voltage measurement	Class 0.5
<b>Serial communication</b>	
Protocol	ModBus RTU
Technology / Type	RS-485

### DHC-96 CPM

Digital instruments: Programmable DC measurement Central

CODE	TYPE	Protocol	Communications	N° relays	Analog output	System	Measurement Range (V)	Measurement Range (A)	Paramètre	Modules
<b>Multimeter</b>										
M223C8	DHC-96 CPM 1500	Modbus/RTU	RS-485	2	1 (20 mA)	DC (Shunt)	$\pm 150 / 300 / 600 / 1000 / 1500$ Vdc	50 / 60 / 75 / 100 / 150 / 200 / 250 / 300 / 400 / 600 mV	V/A/kW/kWh dc	96 x 48

Option of 0/2... 10 VDC outputs on demand



## DHC-96 CPM-HS

Digital instruments: Programmable DC measurement Central

Code: M223B8.

### Dimensions

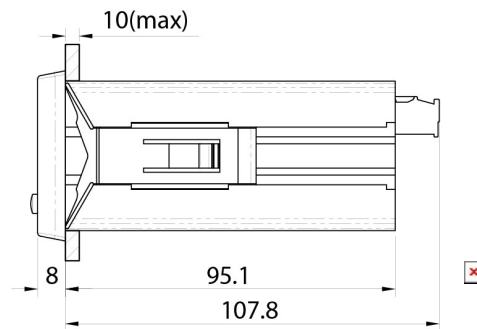
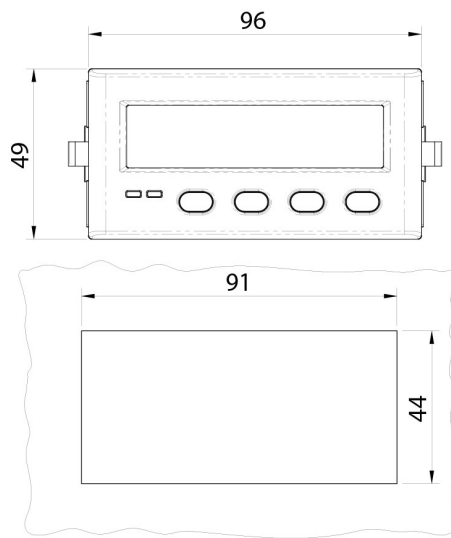

### Connections