



## DCB-72 mAdc

DCB-72 mAdc, digital process indicator 72 x 72

Code: M22260.

- > Scale: -20 ... +20 mA / 0...20 mA / 4...20 mA
- > N° relays: -
- > System: DC
- > Mounting: Pannel
- > Modules: 72 x 72

### Description

Panel-mounted digital instruments that display the value of an electrical variable measured or proportional value of a process signal on its screen (depending on the model). Designed to supervise, regulate and control units with the use of relay outputs that are built in the unit.

The **DCB** series displays the value of an electrical variable measured or proportional value of a process signal on its screen (depending on the model). The unit displays the electrical parameters of a single-phase installation, depending on the model, such as the voltage, current, etc. In DC systems, the unit can measure the voltage, current, frequency and other variables associated with industrial processes. The AC models take the measurements in true RMS (TRMS).

All models in this range have the following features:

- Universal power supply at 80 ... 270 V<sub>ac/dc</sub> and optional power supply at 24 V<sub>dc</sub>
- IP 54 protection degree on the front panel
- High measurement accuracy
- Programmable measuring input
- Alarm delays and interlockings
- Galvanic insulation between external circuits
- Self-configurable decimal point
- Can be installed on 48 x 48 or 72 x 72 mm panels, depending on the model

### Application

These digital instruments have many different applications and can be used in:

- Industrial applications
- Air conditioning units
- Solar photovoltaic energy installations
- Industrial process control systems



## DCB-72 mAdc

Panel-mounted digital instruments

Code: M22260.

### Specifications

#### AC power supply

Installation category	CAT III 300 V
Consumption	1.2 ... 3.3 VA
Frequency	50/60 Hz
Nominal voltage	80...270 V ~

#### DC power supply

Installation category	CAT III 300 V
Consumption	0.6 ... 0.7 W
Nominal voltage	80...270 Vdc

#### Environmental characteristics

Protection class	Frontal: IP54, Rear: IP20
Relative humidity (without condensation)	≤ 95 %
Storage temperature	-40 ... +85 °C
Working temperature	-40 ... +70 °C

#### Mechanical characteristics

Envelope	Polycarbonate + ABS
Weight (kg)	0,18

#### Current measurement circuit

Installation category	CAT III 300 V
Consumption	< 0.2 VA
Nominal current (In)	± 20 mA / 0 ... 20 mA / 4 ... 20 mA
Allowable overload	1.2 In continuous, 10 In instantaneous(5s)

#### Standards

Electrical safety, Maximum height (m)	2000
Electrical safety, Installation category	CAT III 300 V
Electrical safety, Contamination level/class	Pollution resistance 2
Standards	IEC 61010-1, IEC 61000-4-2, IEC 61000-4-3, IEC 61000-4-4, IEC 61000-4-5, IEC 61000-4-6, IEC 61000-4-8, IEC 61000-4-11

#### User interface

Keyboard	4 keys
Display type	LED 5 digits

#### Measurement accuracy



## DCB-72 mAdc

Panel-mounted digital instruments

Code: M22260.

Phase current measurement

0.5 %

### DCB

Digital instrument

CODE	TYPE	Scale	N° relays	System	Modules
<b>Voltmeters</b>					
M22110.	DCB-48 Vac	63,5 V / 100 V / 110 V / 230 V / 380 V / 480 V	-	AC	48 x 48
M22210.	DCB-72 Vac	63,5 V / 100 V / 110 V / 230 V / 380 V / 480 V	-	AC	72 x 72
M22212.	DCB-72 Vac-20R	63,5 V / 100 V / 110 V / 230 V / 380 V / 480 V	2	AC	72 x 72
M22120.	DCB-48 LVdc	± 10 V	-	DC	48 x 48
M22220.	DCB-72 LVdc	± 10 V	-	DC	72 x 72
M22222.	DCB-72 LVdc-20R	± 10 V	2	DC	72 x 72
M22130.	DCB-48 HVdc	± 500 V	-	DC	48 x 48
M22230.	DCB-72 HVdc	± 1500 V	-	DC	72 x 72
M22232.	DCB-72 HVdc-20R	± 1500 V	2	DC	72 x 72
<b>Ammeters</b>					
M22150.	DCB-48 Aac	1 A / 5 A	-	AC	48 x 48
M22250.	DCB-72 Aac	1 A / 5 A	-	AC	72 x 72
M22252.	DCB-72 Aac-20R	1 A / 5 A	2	AC	72 x 72
M22170.	DCB-48 Adc	1 A / 5 A	-	DC	48 x 48
M22270.	DCB-72 Adc	1 A / 5 A	-	DC	72 x 72
M22272.	DCB-72 Adc-20R	1 A / 5 A	2	DC	72 x 72
<b>Process indicators</b>					
M22140.	DCB-48 mVdc	60 mV / 75 mV / 100 mV / 150 mV / 200 mV	-	DC	48 x 48
M22240.	DCB-72 mVdc	60 mV / 75 mV / 100 mV / 150 mV / 200 mV	-	DC	72 x 72
M22242.	DCB-72 mVdc-20R	60 mV / 75 mV / 100 mV / 150 mV / 200 mV	2	DC	72 x 72
M22160.	DCB-48 mAdc	-20 ... +20 mA / 0...20 mA / 4...20 mA	-	DC	48 x 48
M22260.	DCB-72 mAdc	-20 ... +20 mA / 0...20 mA / 4...20 mA	-	DC	72 x 72
M22262.	DCB-72 mAdc-20R	-20 ... +20 mA / 0...20 mA / 4...20 mA	2	DC	72 x 72



## DCB-72 mAdc

Panel-mounted digital instruments

Code: M22260.

### Dimensions

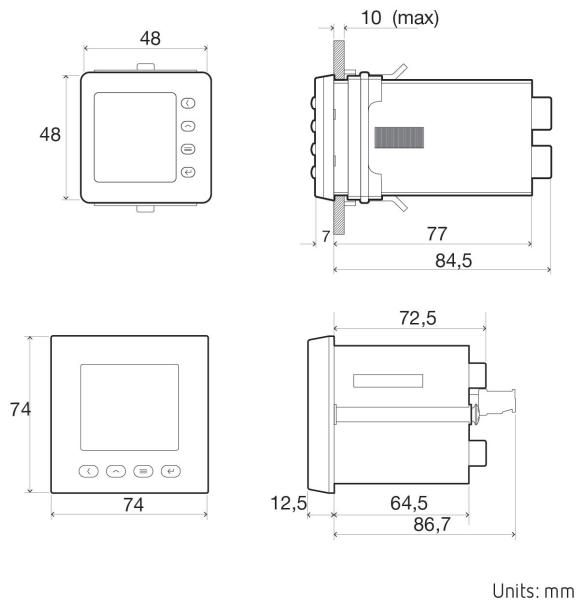

### Connections

