



STM-CN-LoRa F868

STM-CN-LoRa F868, LoRa control module with negative current measurement, 868 MHz frequency,

Code: E82CN20010000 **DESCATALOGADO**

Description

STM is smart analyser that supports up to 32 channels. Designed specifically to supervise photovoltaic strings, the STM allows for the maximum performance of the photovoltaic array thanks to its high measuring accuracy.

The solution consists of different modules:

STM-C: Smart module that is able to calculate powers, compare string performances, detect reverse currents, etc. It also features:

- One 1,500 VDC input
- Four voltage-free digital inputs
- One analogue input 0/4...20 mA
- One input for Pt100 or Pt1000
- A LoRa wireless communications module

STM-S: Current measurement module with 4 measurement channels of up to 42 A each. Up to 8

STM-S modules can be connected to obtain 32 channels.

Its modularity, flexibility of installation, smart characteristics and robustness make the **STM** the perfect piece of equipment to supervise the correct operation of the photovoltaic array.

Application

Supervision of photovoltaic strings in solar farms and self-consumption installations



STM-CN-LoRa F868

Analyser for photovoltaic strings

Code: E82CN20010000

Specifications

DC power supply

Consumption	100 mA
Nominal voltage	24 Vdc \pm 10 %

Environmental characteristics

Relative humidity (without condensation)	5 ... 95 %
Working temperature	-20...+70°C (continuous) -20...+80°C (peak)

Mechanical characteristics

Fastening	DIN rail
-----------	----------

Voltage measurement circuit

Nominal voltage	1500 Vdc
-----------------	----------

Input

Accuracy	\pm 3°C
Range	-25 ... 100°C
Resolution	\pm 0,1 mA
Type	Pt100/1000

Standards

Electrical safety, Installation category	Category II Double-insulated electric shock protection class II
--	---

Analogue inputs

Nominal range	0/4...20 mA
Accuracy	\pm 0,1 mA

Digital inputs

Quantity	4
Type	Optoisolated voltage-free
Maximum short-circuit current	6 mA

The minimum configuration of the STM solution is made up of an STM-C module and an STM-S module



STM-CN-LoRa F868

Analyser for photovoltaic strings

Code: E82CN20010000

Dimensions

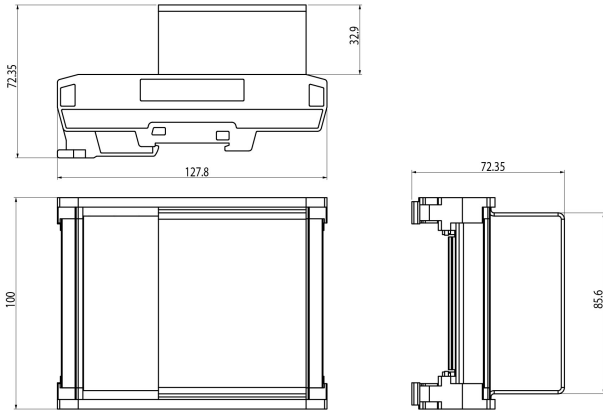

Connections

