



CDP-G

CDP-G, Dynamic power controller with demand management,

Code: E52001. DESCATALOGADO

Description

CDP-G is a dynamic power controller which modifies the MPPT (Maximum Power Point Tracker) of the inverters in order to regulate the PV generation according the energy consumption of the user and besides, it allows using the excesses of PV production. **CDP** product range regulates the PV production according to the power consumption in any self-consumption PV system to control the power that you are feeding into the grid.

CDP-G incorporates **all** the features of the **CDP-O** and moreover it has 3 relay outputs to connect loads and to use the excess of PV production. By connecting non-critical loads during sunny hours in the day it allows to have a lower level of grid dependence and a reduction of energy costs.

By programming a value of power consumption and a priority level to each output, **CDP-G** is able to calculate and to connect automatically each load in the right moment depending on the excess of PV production. Moreover, **CDP-G** allows to assign a percentage of grid contribution to these loads in order improve the performance of the PV system.

Some of the main features of the **CDP-G** are:

- Management of 3 loads
- Usage of PV production excess
- Web monitoring (smart-phones, tablets or PC)
- Data logger and file downloading (.csv) through any web browser
- Web configuration of many parameters
- Display with on-line data of PV production, user consumption and grid consumption
- MODBUS/TCP communications to allow SCADA integrations.

Application

- Self-consumption PV systems (with/without) grid injection with usage of PV production excess
- Remote monitoring systems and energy balance trending (with or without grid injection)
- Management of heat pumps (aerothermal or geothermal)
- Water heating with the use of thermoaccumulators (swimming pools, homes)
- Water pumping and irrigation applications
- Production of compressed air.



CDP-G

Dynamic power controller with demand management

Code: E52001.

Specifications

Mechanical characteristics

Size (mm) width x height x depth	105 x 90 x 65 (mm)
Weight (kg)	0,319

Requires MC (.../250 mA) series current transformers



CDP-G

Dynamic power controller with demand management

Code: E52001.

Dimensions

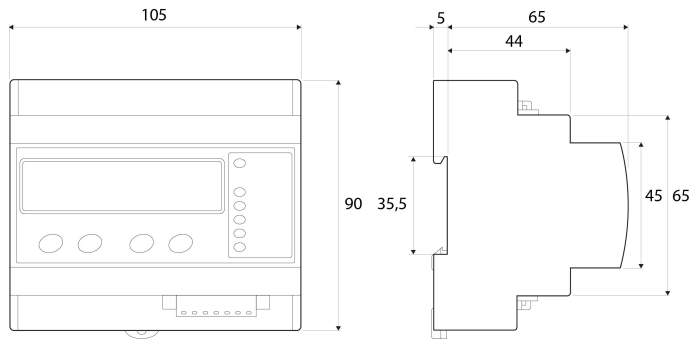

Connections

