

AFQm

30 / 60 /100

Active filter with multilevel technology



AFQm 30



AFQm 60



AFQm 100

Description

The wall-mounted AFQm multilevel active filters are the most complete solution for solving power quality problems in three-phase industrial, commercial or service installations caused by the presence of harmonics and the consumption of reactive power. These following characteristics and functions have been implemented:

- Filtering capacity of 30 A, 60 A and 100 A
- Small wall-mounted cabinet easy to install thanks to its small dimensions
- Range for installations with 3 wires (3W model) or 4 wires (4W model)
- Multi-range voltage and dual frequency (50/60 Hz)
- Reduction of harmonic currents up to the fiftieth harmonic (2,500 Hz)
- Selection of harmonic frequencies to be filtered for maximum filter effectiveness
- Power factor correction both inductive and capacitive
- Phase current balancing, improvement of consumption in neutral (4W model)

If higher filtering capabilities are required, up to 100 filters can be connected in parallel (the filters must all be of the same 3 or 4-wire model).

Applications

They are an ideal solution for installations with a large amount of single-phase and three-phase loads generating harmonics, such as computers, UPS units, lights, lifting equipment, air-conditioning systems with variable speed drives, etc.

They can also be used in installations that require a good power quality for the purpose of increasing production efficiency and improve supply continuity in the system.

Technical features

Electrical characteristics	Rated voltage	4 wires (4W) 3P+N: 230...400V phase-phase +/-10%			
		3 wires (3W) 3P: 230...480V phase-phase +/-10%			
	Frequency	50/60Hz +/- 5%			
	Maximum THDv	25%			
Power	Models	30 A	60 A	100 A	
	Maximum power	4W (400V) 3W (480V)	20700 VA 22906 VA	41400 VA 45812 VA	69000 VA 76300 VA
	Average efficiency	>97.2%			
	Maximum current (phase)	30 A (rms)	60 A (rms)	100 A (rms)	
	Maximum current (neutral) only 4W	90 A (rms)	180 A (rms)	300 A (rms)	
	Features	Filtering	From the 2nd to the 50th harmonic, selectable Time response < 0.1 ms		
	Phase balancing	Selectable			
	Power factor correction	Selectable from 0.7 inductive to 0.7 capacitive			
	Programming priority	Priority of filtering or balancing / Power factor correction, selectable			

AFQm

30 / 60 /100

Active filter with multilevel technology

Features	Models	30 A	60 A	100 A
Parallel installation		<ul style="list-style-type: none"> · Up to 100 devices/modules · Connection of CTs to the master unit · Allows redundancy (system operation in the event of equipment failure) 		
Noise level		<52 dBA	<54 dBA	<60 dBA
User interface		3.5" colour touchscreen Web server and datalogger		
RS-485		Modbus RTU, 9600, Stop 1 No Parity		
Ethernet		TCP/IP (Modbus TCP)		
Installation	Category	CAT III (300 V)		
	Pollution rating	2		
	Working temperature	-10... +45°C		
	Storage temperature	-20... +55°C		
	Relative humidity	0...95% non-condensing		
	Maximum altitude	3000 m (2000 m without derating)		
	Protection degree	IP20 (or other protection degree upon request)		
	Models	30 A	60 A	100 A
Grid		M6 Ring terminal	M6 Ring terminal	M8 Ring terminal
		Maximum ring width 12 mm	Maximum ring width 12 mm	Maximum ring width 23 mm
		Tightening torque 2.2-2.4 Nm	Tightening torque 2.2-2.4 Nm	Tightening torque 8-10 Nm
CTs		6-pole connector Maximum cable cross section 2.5 mm ² Tightening torque 0.5...0.6 Nm		
RS-485		3-pole connector Maximum cable cross section 2.5 mm ² Tightening torque 0.5...0.6 Nm		
Ethernet		RJ45		
Standards	IEC 62477-1:2012, IEC 55011:2011, IEC 61000-6-2, IEC 61000-6-4:2007, IEC 61439-1:2011			

AFQm

30 / 60 / 100

Active filter with multilevel technology

Dimensions

Type	Dimensions (Width x Height x Depth)	Weight (kg)
AFQm-3WF-030M-480	430 x 530 x 178 mm	21
AFQm-3WF-060M-480	430 x 530 x 348 mm	39
AFQm-3WF-100M-480	439 x 745 x 288 mm	56
AFQm-4WF-030M-400	430 x 530 x 178 mm	21
AFQm-4WF-060M-400	430 x 530 x 348 mm	39
AFQm-4WF-100M-400	439 x 745 x 288 mm	56

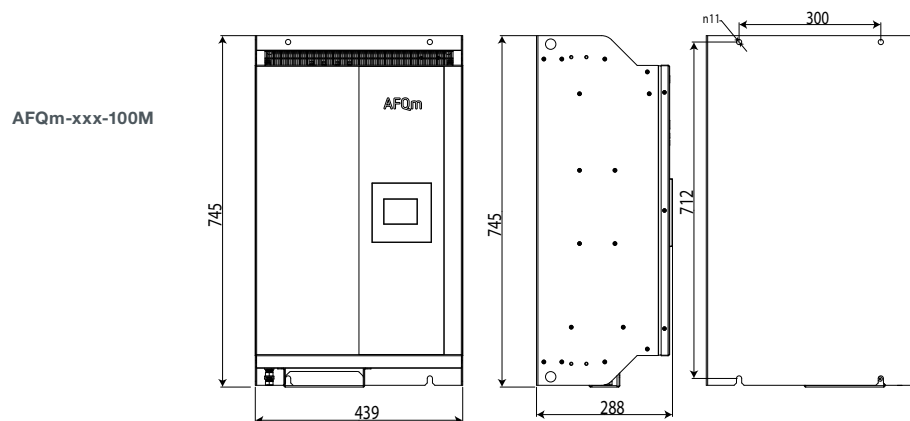
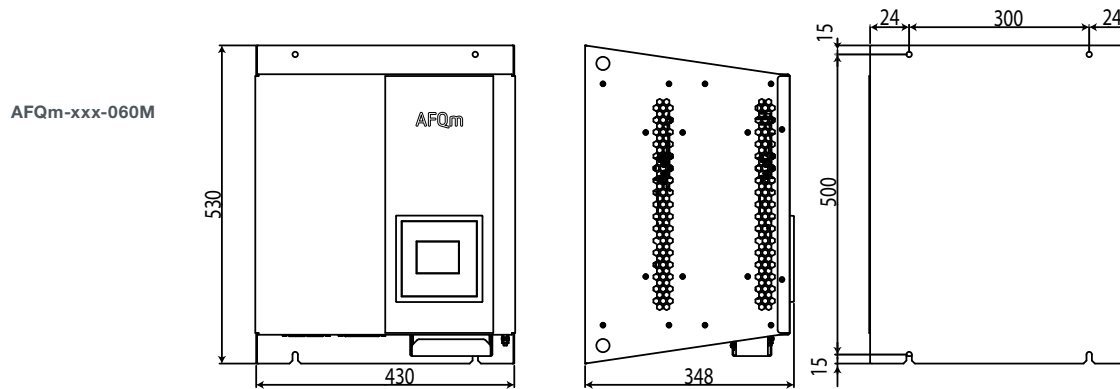
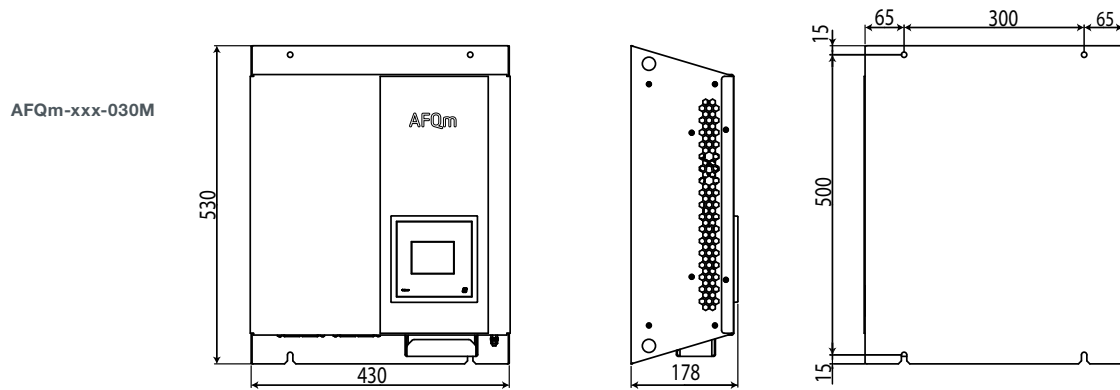

AFQm

30 / 60 / 100

Active filter with multilevel technology

References

Wall-mounted active filters for 3 wires (3W) and 4 wires (4W)

Phase current	Neutral current	System	Type	Code
30 A	-	3 wires 230V - 480 V	AFQm-3WF-030M-480	R7MM0F
60 A	-		AFQm-3WF-060M-480	R7MM1F
100 A	-		AFQm-3WF-100M-480	R7MM2F
30 A	90 A	4 wires 230V - 400 V	AFQm-4WF-030M-400	R7RM0F
60 A	180 A		AFQm-4WF-060M-400	R7RM1F
100 A	300 A		AFQm-4WF-100M-400	R7RM2F

All active filters incorporate an EMI filter

Connections

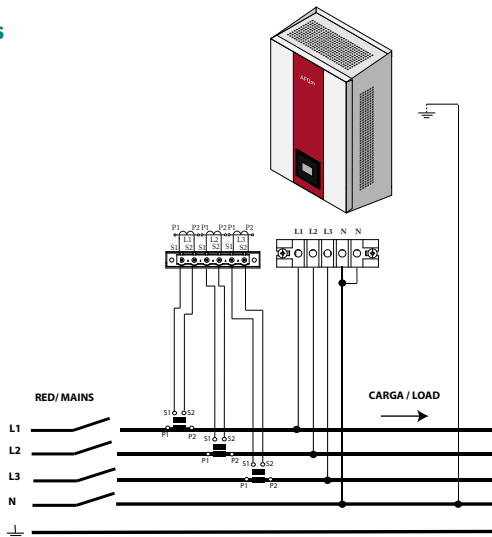

Three-phase measurement with 4 wire power connection and current measurement in mains side.

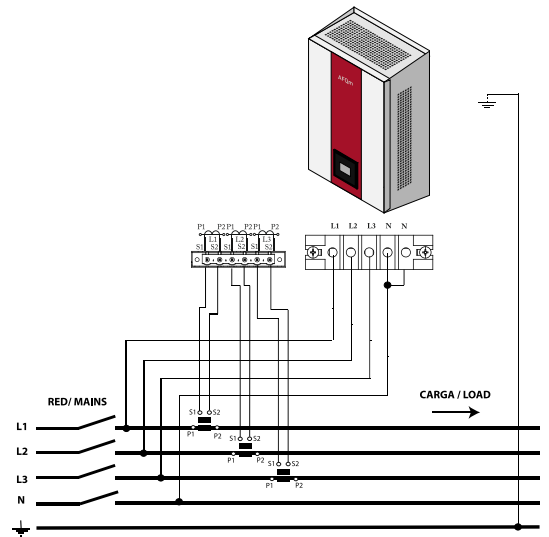

Three-phase measurement with 4 wire power connection and current measurement in load side.

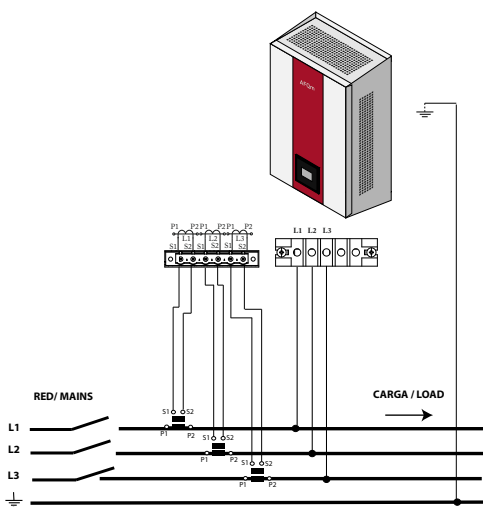

Three-phase measurement with 3 wire power connection and current measurement in mains side.

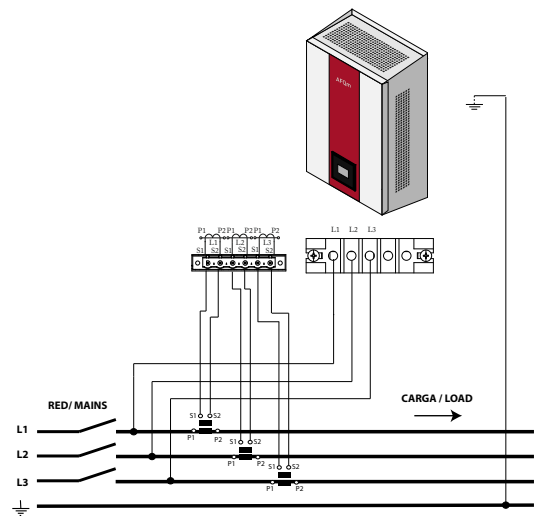

Three-phase measurement with 3 wire power connection and current measurement in load side.